

## Installation Guide

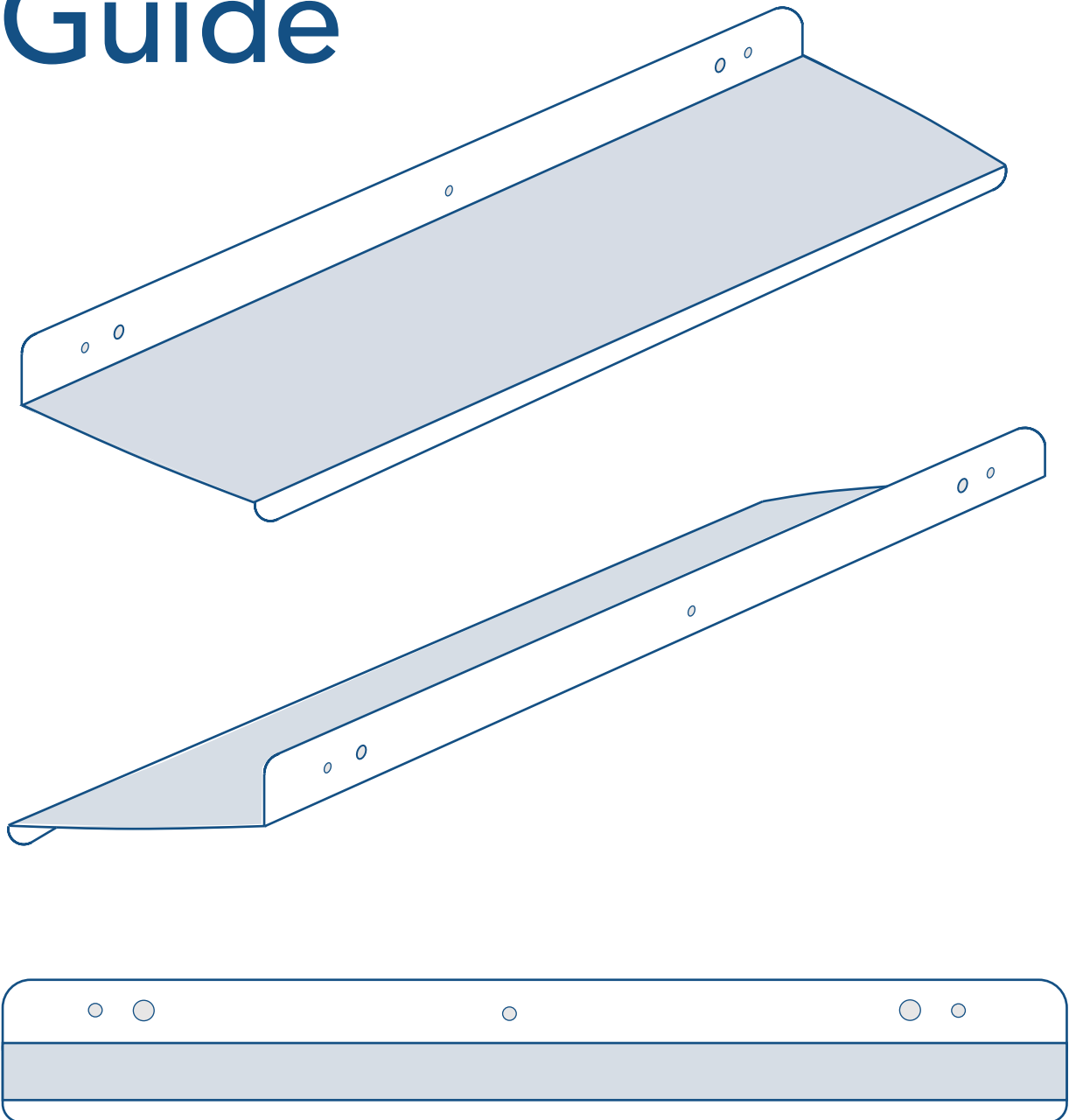

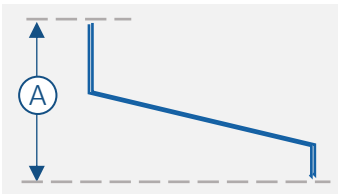

Scribe a horizontal line on the walls surface. This line is the top edge of RainDeflect incorporating a 20mm clearance for the opening door swing.

1

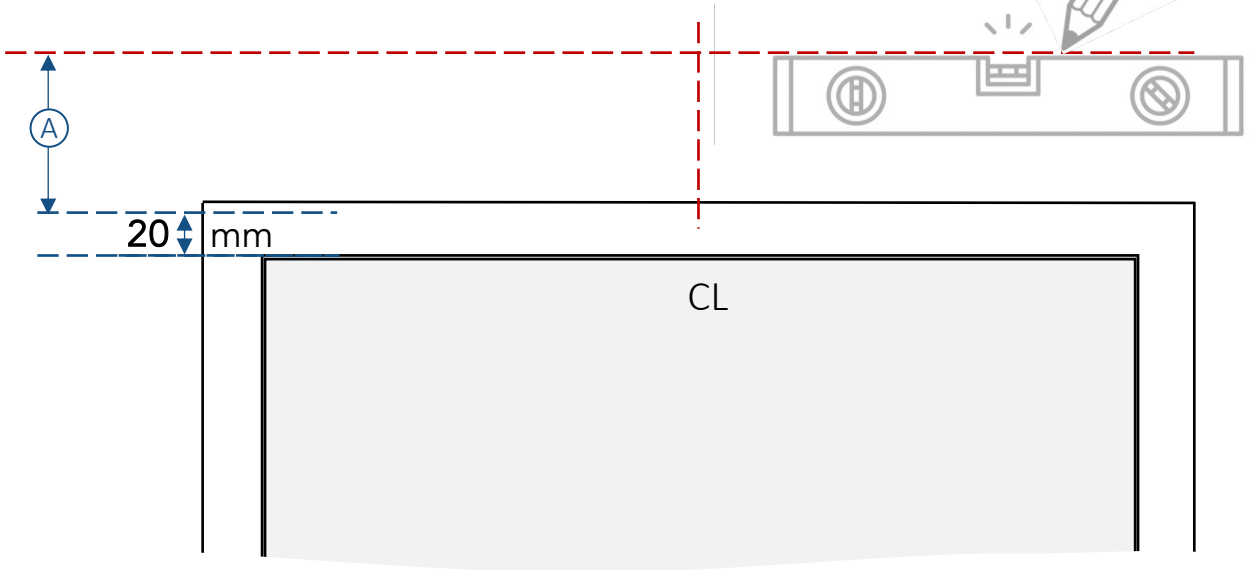

Identify center of the door and scribe vertical line on the wall

Hand place RainDeflect in position and mark up holes on wall.  
*(can use center hole to align RainDeflect to vertical line)*

2

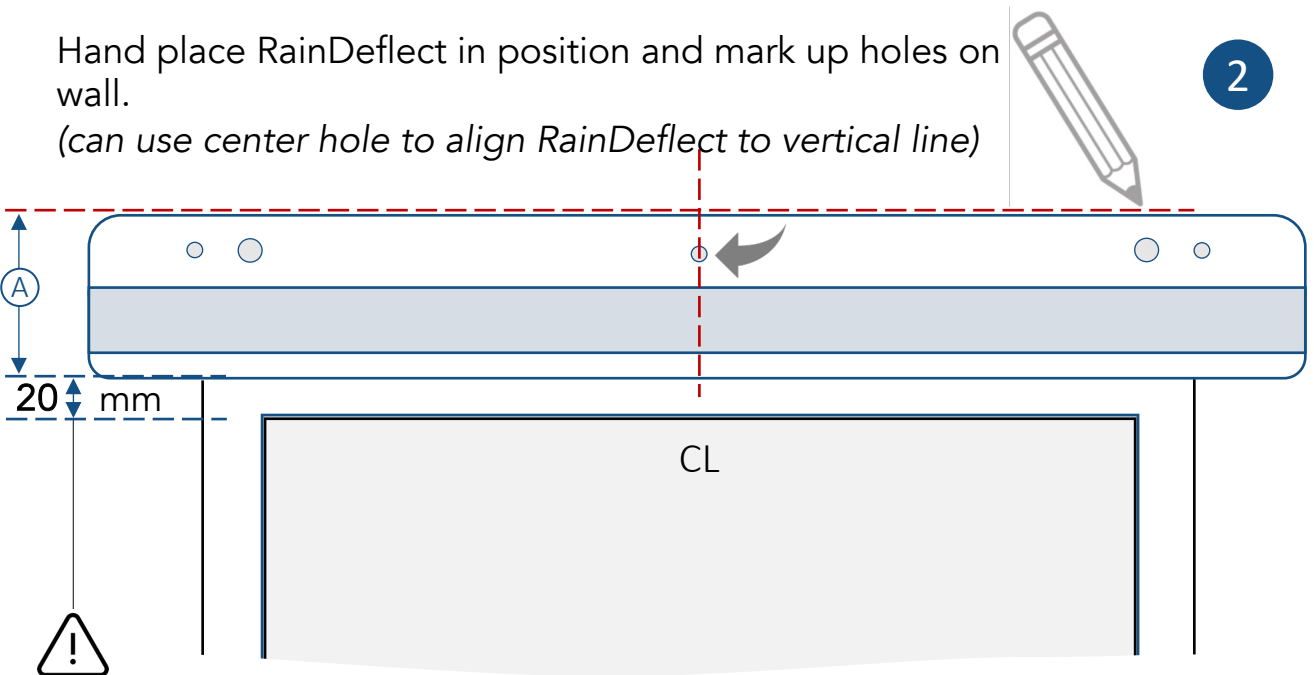

Hand place RainDeflect to check top of door open swing clearance. Ensure a recommended minimum clearance of 20mm to the bottom of RainDeflect lower lip.

Select fixing method depending on wall composition eg: Screw fix or masonry anchor fix.

3

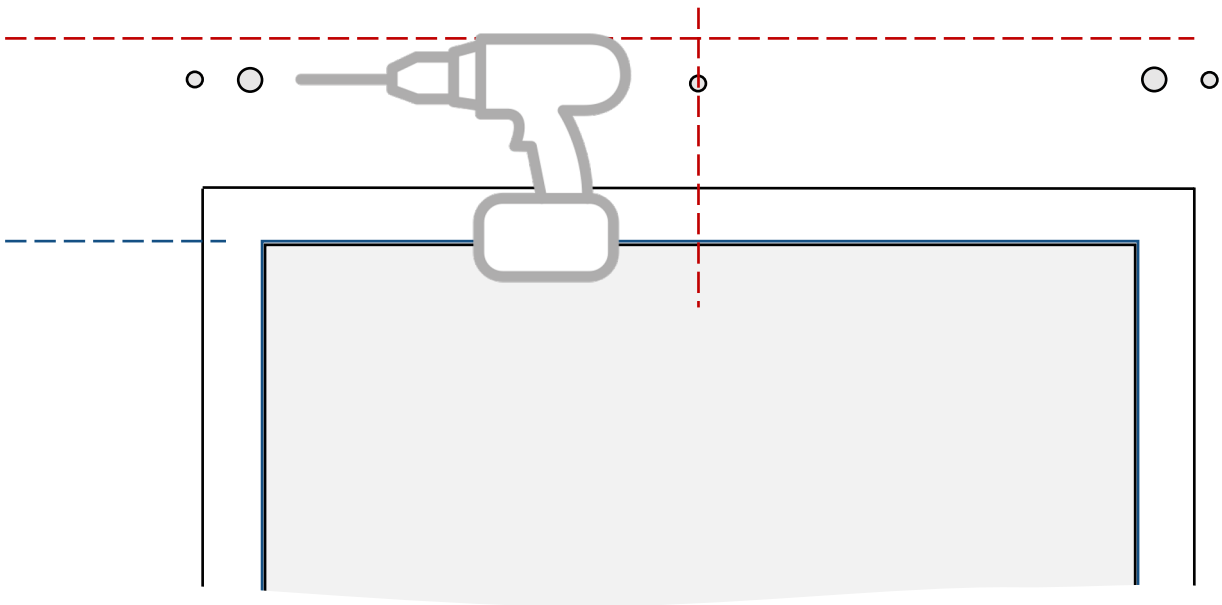

Apply two beads of waterproof adhesive sealant on the wall facing side of RainDeflect as shown. Ensure complete coverage end to end.

4

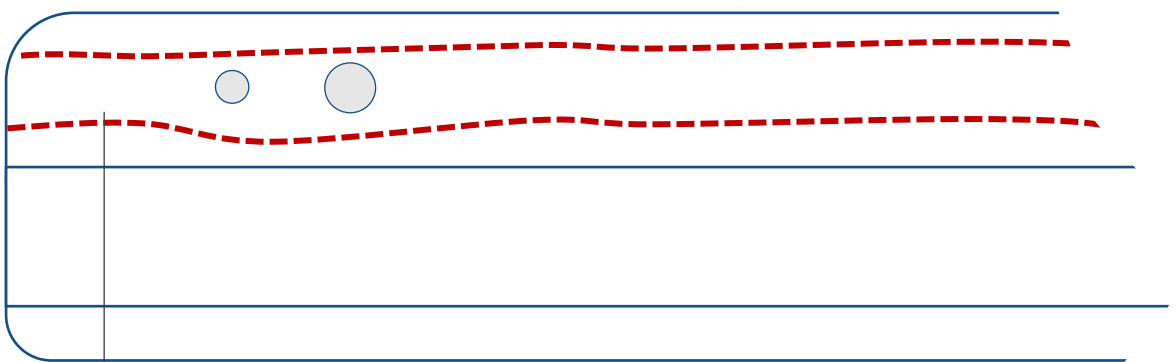
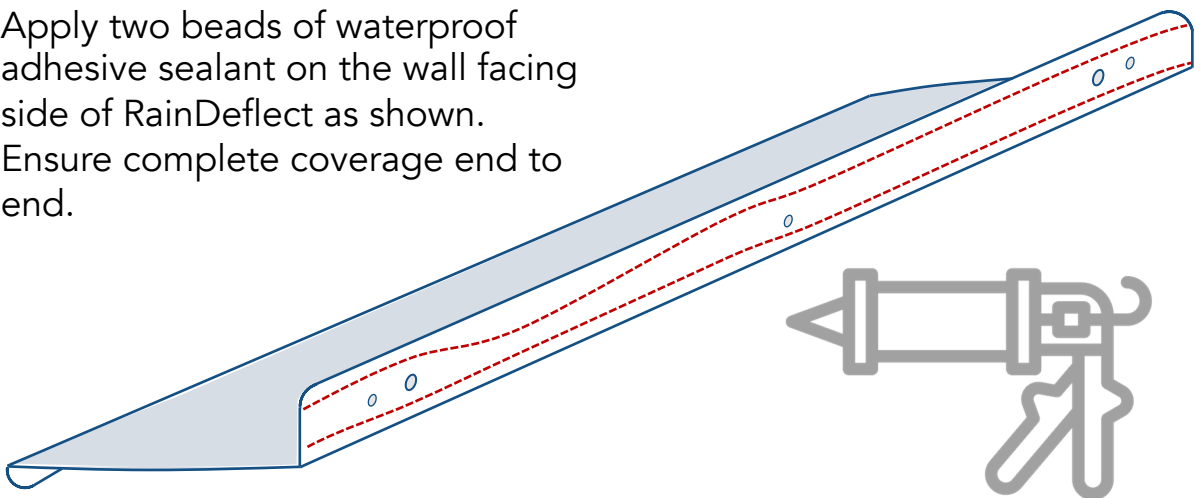

Ensure 2 Rows of sealant. One top and one bottom of holes

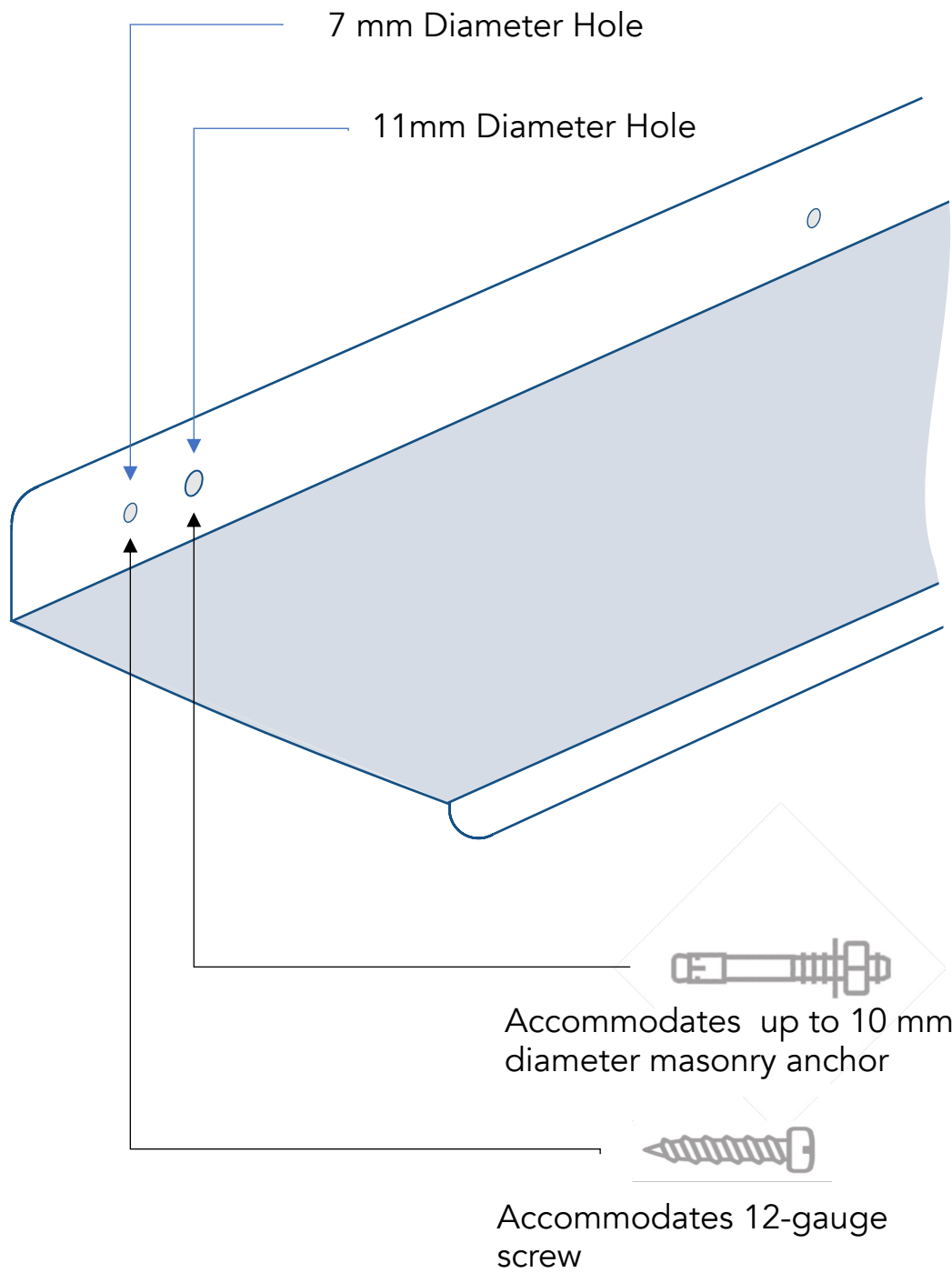

Disclaimer: This product must be installed by a suitably qualified and licensed tradesperson in accordance with all applicable Australian Standards, building codes, and local regulations. The installer is solely responsible for assessing site conditions, verifying structural adequacy and substrate suitability, determining appropriate fixing methods, and ensuring correct installation. The manufacturer accepts no responsibility or liability for any loss or damage arising from incorrect installation, failure to follow these instructions, site-specific conditions, improper use, modification, or non-compliance with applicable standards. To the extent permitted by law, the manufacturer's liability is limited to replacement of the product or refund of the purchase price, and excludes liability for any indirect, incidental, or consequential loss or damage. Nothing in this disclaimer excludes, restricts, or modifies any rights or remedies available under the Australian Consumer Law that cannot be lawfully excluded.